

Date:

Bid Date:

Project Name:

Project #:

City/St/ZIP:

Engineer:

Contractor:

Fuel Type:

Natural Gas

Propane

Factory Option:

iNTouch-BMS

Key Features

- **Multiple Stainless** (316L) heat exchanger
- **Flexible-Floating** Design, stress relieving and thermal shock capable.
- **Built in Redundancy**- Multiple heat engines with individual control.
- **Multi-Unit**- masterless cascading with common venting
- **Gas Pressures**- Operates on gas pressures range of 2.5"-14" w.c.
- **ASME-HLW compliant**
- **Designed and Built** in the U.S.



Performance

- Turndown Ratio of 25:1 per unit.
- Cascade up to 4 units with common venting for a total of over 3000MBH and a 100:1 total turndown ratio

	Temperature Rise (ΔT) °F						
	40	50	60	70	80	90	100
Flow (GPM)	35.4	28.3	23.6	20.2	17.7	15.7	14.2

Pressure Drop

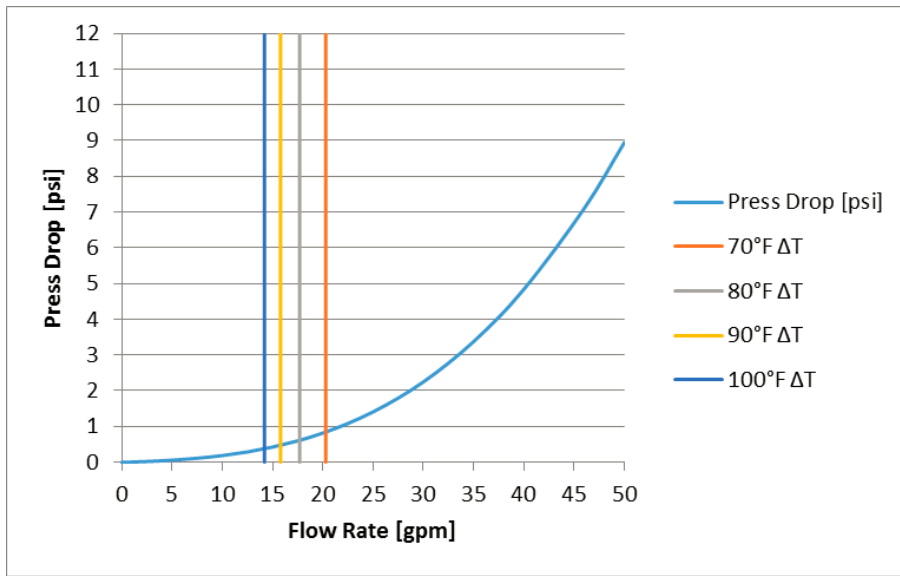

Clearances

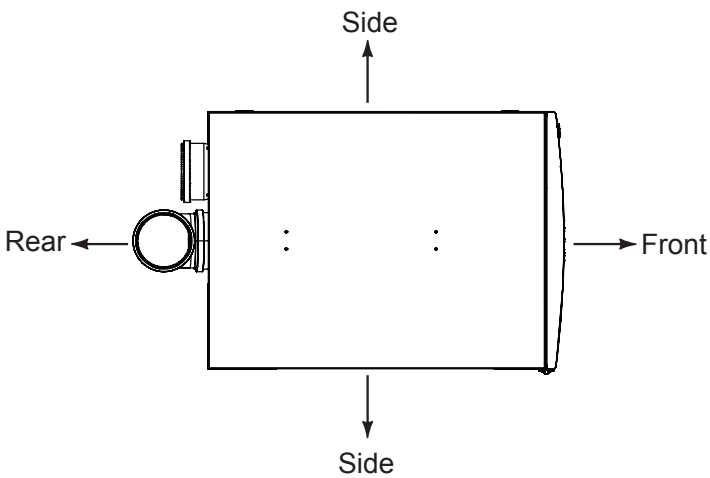

Required Mounting Clearances			
Location	From Combustibles	From Non-Combustibles	Service Clearance ¹
Top	6" (15.2cm)	20" (50.8cm)	18" (46cm)
Back	5/8" (15.8mm)	5/8" (15.8mm)	24" (61mm)
Sides	1" (25.4mm)	1/2" (12.7mm)	24" (61mm)
Front	2" (5.1cm)	2" (5.1cm)	32" (81cm)
Bottom	0" (0mm)	0" (0mm)	0" (0mm)

¹ Service clearances are suggested to allow for normal service

Venting

Maximum Vent Length (ft.)					
Number of units vented together	Venting Type	Duct Size			
		6"	8"	10"	12"
1	1 pipe - PV	220	500	-	-
	2 pipe - DV	110	250	-	-
2	1 pipe - PV	-	252	500	-
	2 pipe - DV	-	127	250	-
3	1 pipe - PV	-	120	360	500
	2 pipe - DV	-	60	180	250
4	1 pipe - PV	-	70	212	500
	2 pipe - DV	-	35	106	250

Note: Reduce the maximum equivalent length above by 5 feet per 90° elbow and by 2 feet per 45° elbow used. Do not exceed the above set limits. PV = Power vent, DV = direct vent

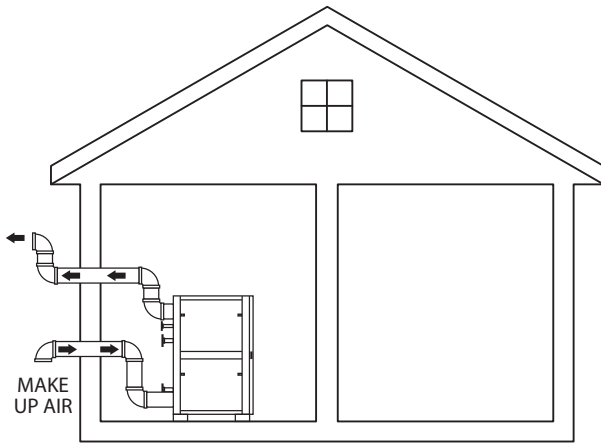

Ex: 2-Pipe Direct Vent

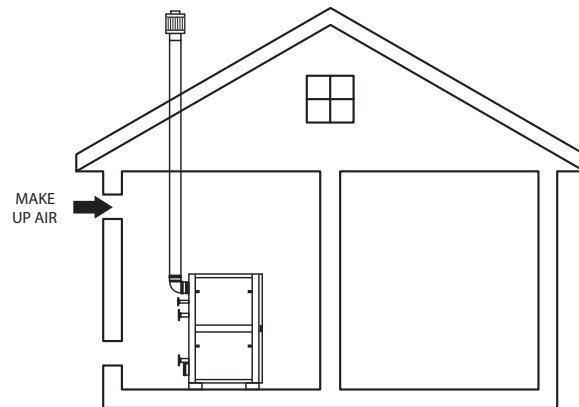

Ex: 1-Pipe Power Vent

Electrical Data

Electrical power required for the water heater is 120V AC, 60 Hz. The circuit breaker shall be sized for a maximum power consumption of 20 amps for a single heater. Larger breakers can be used for multiple units. Please ensure correct polarity of wiring before powering up unit.

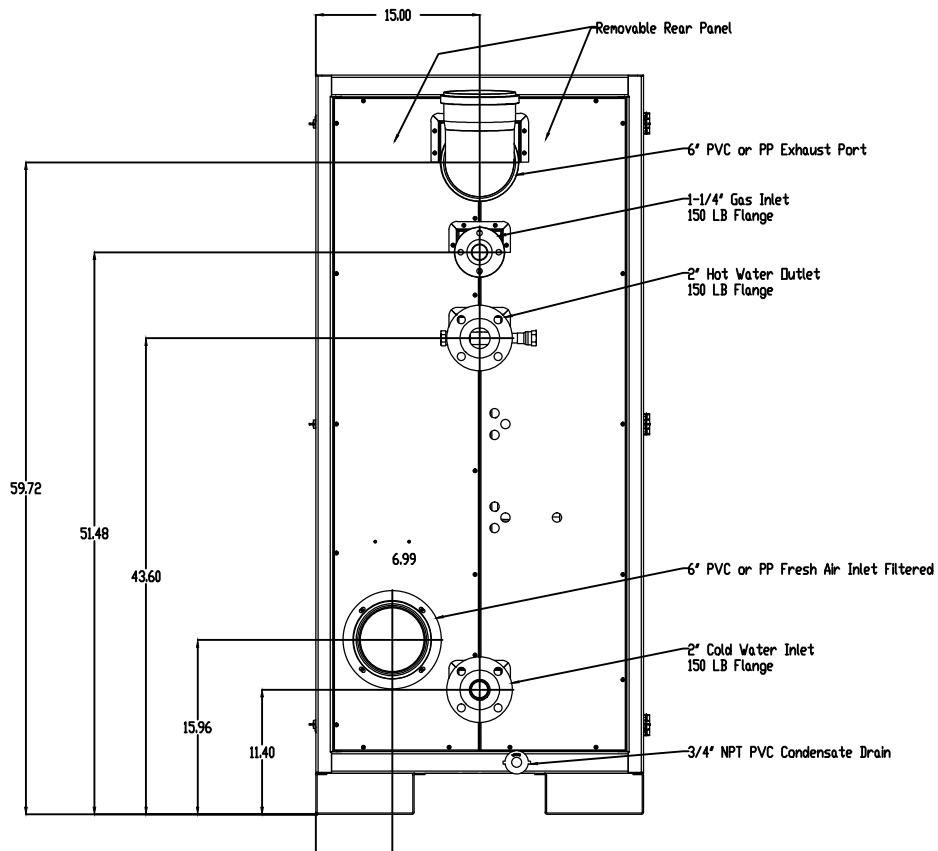
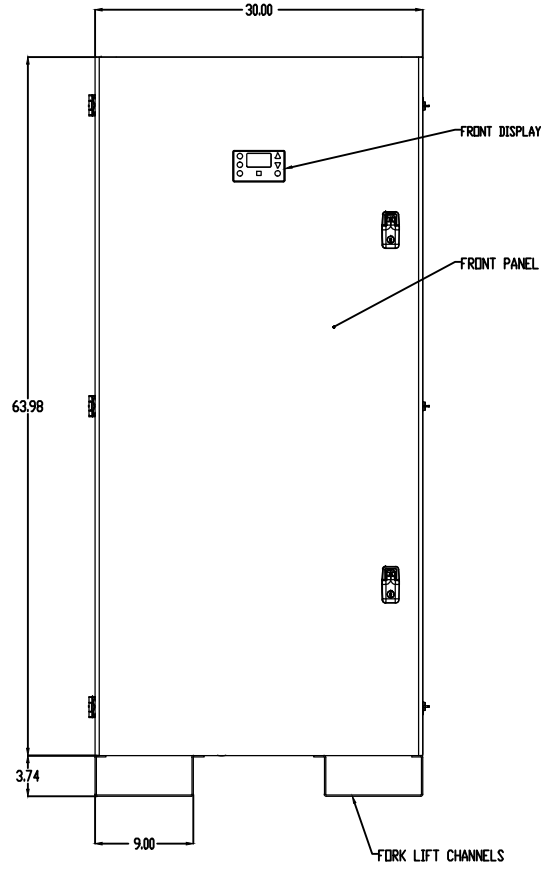

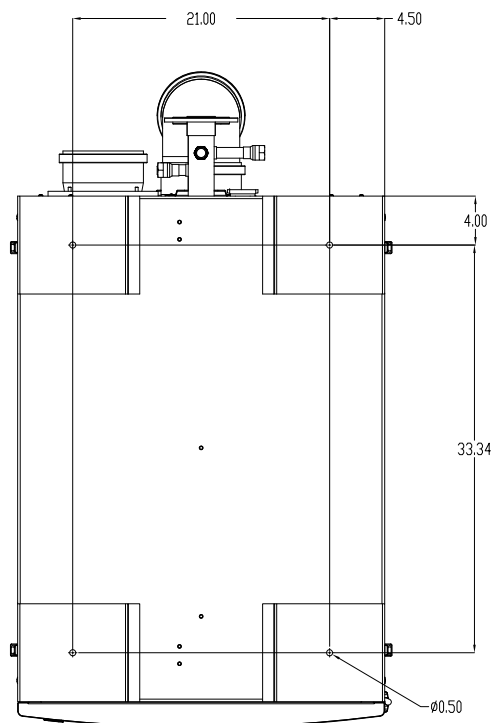
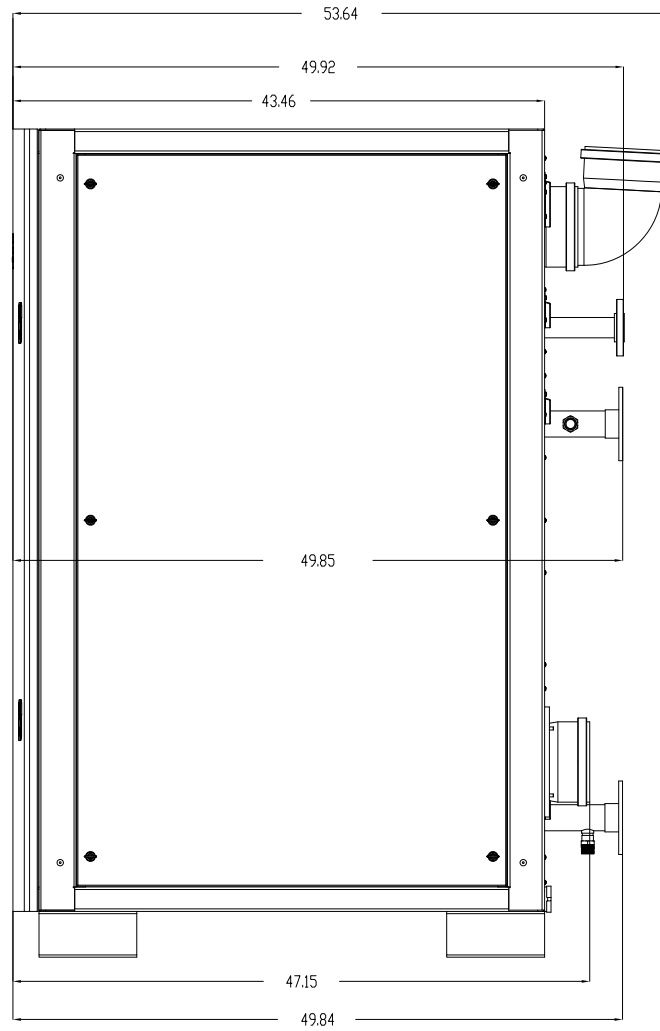

PARAMETERS	iQ751
Type	Indoor, Floor Mounted, Condensing, Fully Modulating, On-demand Water Heater
Fuel	Preset for NG / LP convertible without additional parts
Minimum Input (Btu/h)	30,000
Maximum Input (Btu/h)	751,000
Maximum Output (Btu/h)	706,000
Thermal Efficiency	94%
Turn Down Ratio (TDR)	25:1
Water Inlet / Outlet Connections	2" Headers with 6" OD Flange
Gas Inlet Connection	1-1/4" Gas Inlet With 4-5/8" OD Flange
Condensate Drain Connection	3/4" Flex PVC
Maximum Condensate Flow Rate (GPH)	5.4
Dimensions H X W X D (inches)	64 X 30 X 43.4 (48 cu. ft)
Service Clearances	Recommend 24" on all sides
Weight (lbs)	525
Venting Type	Direct Vent (2 pipe - intake & exhaust), Power Vent (1 pipe - exhaust only)
Venting Materials (USA)	Sch. 40 PVC, Sch. 40 CPVC, Polypropylene, Stainless Steel
Venting Materials (Canada)	Type BH Gas Vent Classes: II A (PVC), II B (CPVC), II C (Polypropylene), I (AL294C SS)
Vent Size (Diameter)	6" Ø
Max 6" Vent Length - Single Pipe / Power Vent	220 ft*
Max 6" Vent Length - Two Pipe / Direct Vent	110 ft*
* Venting Note: From the maximum lengths above, deduct 5 ft. per 90° elbow and 2 ft. per 45° elbow	
Ignition	Electronic Spark Ignition
Temperature Range	100°F - 190°F
Temperature Stability	+/- 4°F
Installation Location Ambient Temperature	40°F - 130°F
Safety	Flame Rod, Thermal Fuse, Overheat Prevention Device, Fan Speed Monitor, Flue Temperature Monitor, Blocked Vent Detector, Dual Flame Sensing
Water Pressure Min / Max (PSIG)	30 / 160
Pressure Relief Valve	1" Ø / Select Btu/h Input Rating to match Model Maximum Input / 160 PSIG
NG/LP - Min. Dynamic Gas Pressure (Full Fire)	2.5" (non-corrugated, black iron)
NG/LP - Maximum Static Gas Pressure	14"
Gas Pressure for Adjustments	8" for NG, 11" for LP
Electrical	120V AC, 60 Hz
Power Consumption	Max 16 Amps, 24W (Standby)
Internal Water Volume (gallons)	3
Features	
High Turn Down	25:1 TDR per iQ751; 100:1 TDR (4 x iQ751)
Built-In Redundancy	Multiple Heat Engines w/ Individual Control
Cascading	Masterless, 4 units, Automatic Rotation
Common Venting	Yes - up to 4 units
Heat Exchanger	Expandable, Stainless 316L
Listing	ETL (Z21.10.3 / CSA 4.3), ASME HLW
Performance	
	GPM
Hot Water Capacity (45F Rise)	31.5
Hot Water Capacity (70F Rise)	20.2
Hot Water Capacity (90F Rise)	15.7
Hot Water Capacity (100F Rise)	14.2
Hot Water Capacity (140F Rise)	10.1
Warranty	Heat Exchanger Coil - 10 years, All Other Parts - 2 year

Note: due to Intellihot's policy of continuous product improvements, design and technical specifications are subject to change without notice. 02/18/16



Intellihot Green Technologies Inc.
 2900 W. Main Street, Galesburg, IL 61401 · phone: 877.835.1705
 email: sales@intellihot.com · www.intellihot.com

